

Simulation & Analysis of Dc Micro Grid with Power Quality Improvement

Mr. Nisarg Swami¹ and Prof. Ghuge Nilam Nimraj²

¹Ph.D. scholar , Department of Electrical Engineering , University of Technology- Jaipur , Rajasthan

²Associate Professor , Department of Electrical Engineering, JSPM's Bhivarbai Sawant Institute of Technology & Research , wagholi ,Pune , Maharashtra

ARTICLE INFO

ABSTRACT

Received: 24 Aug 2024

Revised: 12 Sept 2024

Accepted: 26 Oct 2024

In the evolving era micro grid is the core area in all power fields. Now a day's DC micro grid system have haggard additional attention because of, the rising use of dc energy, energy storing system and loads in control system Managing of power and energy are the growing qualities adopted by researchers present days. The DC Micro grid is more reliable than AC because of less complex structure, cost is low, and control scheme is easy compare to AC Micro grid system. Main aim of this topic is analysis of different power quality issue, Structure and operational mode of DC Micro grid. Distributed generation with renewable sources is becoming a potential trend in technology. DC load have proliferated quickly on the market nowadays and DC micro grids with renewable energies are existence made a possible solution to chance the growing demand for energy. DC Micro grid system connected with PV array supplying power to the DC bus by the DC-to-DC boost converter. Duty ratio of this converter is control by P&O algorithm. And boost converter boosts up the PV array voltage. This simulation able to cancel out the photovoltaic voltage oscillations. It provides smooth power flow using Shunt Active Power Filter.

Keywords: DC Microgrid, SAPF, MPPT, PMC,etc.

I. INTRODUCTION

A micro grid is a collection of small-scale electrical sources that can be AC, DC, or hybrid and use renewable energy as their primary source of power. Micro grids can function independently through the utility grid. As the usage of renewable energy sources, energy storage, and DC integral loads expanded, so did the use of DC micro grids in the power industry. Power conversion steps are cut down with a DC micro grid. It is advantageous over AC micro grids in that it does not require frequency, phase, or reactive power regulation during operation.

Although energy storage systems are a viable option to address renewable intermittency and boost the grid's use of renewable energy sources, they can generate income by charging them when local electricity prices are low and discharging them when prices are more. The electiveness of the planned idea is shown by simulation & results. The integration of DC micro grids provided for the constant power, it is mostly important in urban areas where utility grid is not presented. A micro grid is made up of interconnected distributed energy sources that can provide a sizeable amount of the energy needs of internal loads continuously. The DC micro grids mitigate some problems with the help of different controlling methods. A micro grid's boost converter may accommodate a wide range of input voltages and a wide range of output voltages from various sources by using it. In order to distribute energy to the users, PV array are together to a Main grid. The grid is connected DC PV systems & maximum power point tracking performances in the dc region. There are mainly three different types of micro grid being used in present scenario. it is described in below.

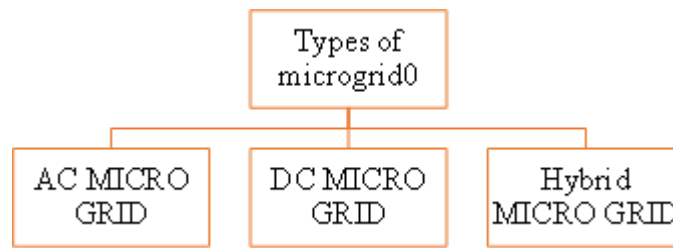

Fig.1- Types of Microgrid

II. DC MICROGRID CONCEPT

DC Microgrid:-

Due to the rise in recent DC loads like electric vehicles, LED lights, & the fact is greater part of electronic gadgets are DC, it is a developing technology. here regard, DC grid has demonstrated the breadth of its application. A DC micro grid links to a multiple grid through the PCC, much like an AC microgrid does, allowing for seamless connects and detach transitions. Using a single step DC-DC converter, DC micro source like solar, Battery & loads can quickly be connected to

a dc bus. Rectifiers with controllers are all that are needed to interact with the DC bus for AC loads like moving machinery. AC generators like wind turbines. In a less similarity between DC & AC micro grids in suburban buildings, the author discovered that DC micro grids are extra efficient in power transfer losses. In addition, when an ESS is used, the minor loss of DC micro grids can be significantly greater than that of AC counterparts DC network, which necessitates network restructuring and requires a significant investment.^[6]

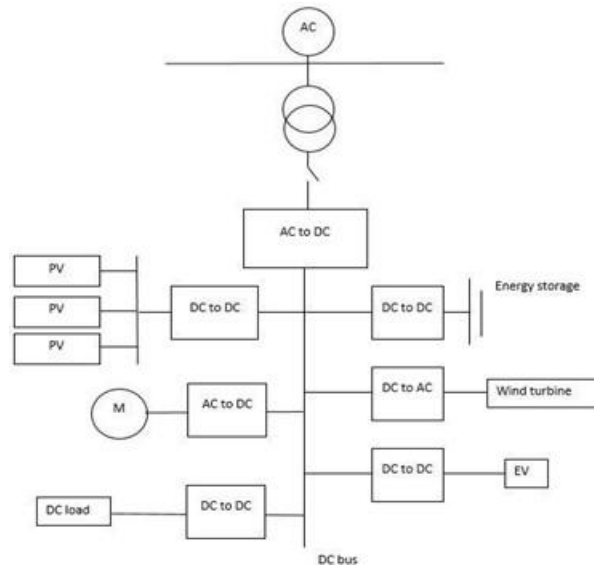

Fig.2- DC Microgrid Concept

Hybrid Micro grid:-

Hybrid micro grid is one that has both connected AC & DC MG. An AC/DC unidirectional converter is typically used to connect a DC micro grid to the AC bus while it is connects directly to the PCC in a hybrid. hybrid topology essentially combines the topologies of both Micro. A hybrid micro grid is specific type of AC grid network that is coupled to a sub-DC microgrid; this architecture is more efficient than an AC MG. In a hybrid micro grid, an AC-DC converter serves the primary converter linking the AC micro grid & DC microgrid. This converter controls the power flow of this two subsystems. In addition, coordination manage of multiple converter is crucial for a hybrid microgrids stability and efficiency.^[8]

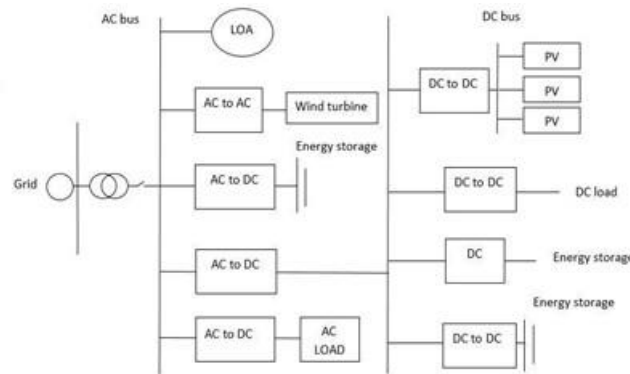

Fig.3- Hybrid Micro grid

Research Area of power quality improvement in Grid system: The most important attention of this dissertation is on power quality problems & controlling methods linked to micro grid. The grid interaction of renewable energy systems with enhanced performance parameters is the primary subject of research including both academia and industry. The power quality problems such as current harmonics and oscillation in voltage when it is integrated with AC microgrid.

Motivation:

The main motivation for this dissertation is the increasing importance of DC micro grid and its application. Suggest an idea for the construction of a grid connected PV system. There are various advantages of DC micro grids:

- This is chiefly due to the absence of warning equipment.
- Small PV DC micro grid makes extra financial sense.
- Reliability is more.
- Higher transmission efficiency.
- Cheaper converter circuits which can offer extra cost savings in addition to the cost savings associated with using renewable energy sources
- A DC micro grid can simply integrate with the renewable sources to reduced steps of power converters.

Objectives:

- To study about the different micro grid structure and its performance for different load.
- To study and understanding different power quality issues in grid system.
- To analysis harmonics in power grid integrated with power converter for different load.
- To prepare Micro grid structure based on solar PV panel in MATLAB.
- To analysis power quality issues while DC micro grid connect with AC power grid.
- To improve power quality and enhance the gird performance.
- Calculate THD

III. PROPOSED SYSTEM

Fig-4 describes the basic working and flow of DC micro grid system through a block diagram that consist PV array, power converter and MPPT algorithm. This proposed system consists of following Parameters:

➤ **PV Array**

- **Boost converter**
- **P&O MPPT Technique**
- **Inverter**
- **AC Power Grid**
- **Battery**

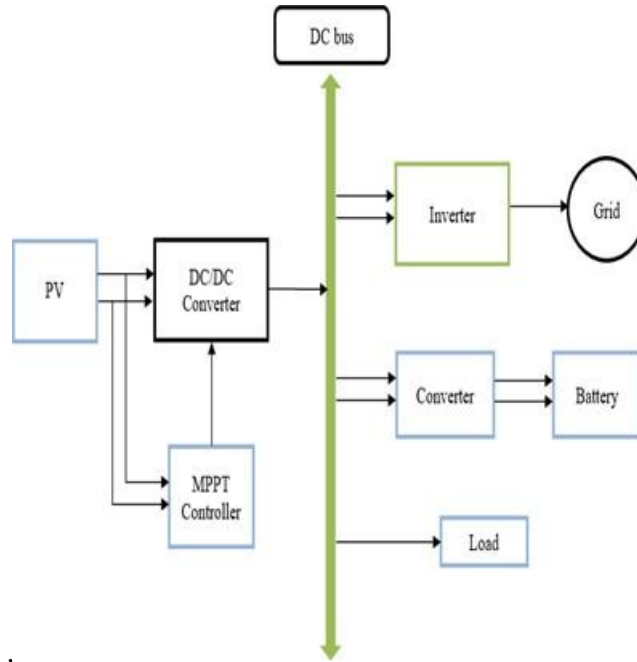

Figure 4 Proposed DC Microgrid System

This proposed scheme involves a PV system with P&O technique. Boost converter, PWM inverter & control strategy, DC to AC inverter & controller. This converter reduces the component losses & improves the concert of the whole system with good dynamic response. Maximum power provides by MPPT Technique. the simple drawing of the whole system is shown in Figure 1, this planned system designed & employed in MATLAB, this DC supply convert in to AC through inverter, it is connected with the loads. Maximum power Provide through P&O algorithm. In boost converter circuit power electronics based mosfet is used. The gate pulse of mosfet provide by PWM generator it's connected with P&O algorithm to maintain the duty ratio. PWM Inverter is used to convert DC in to AC, it is a three-phase inverter consist power electronics switches, gate pulse for the switches provides by PWM generator and switching sequence adjust in this. DQ Transformation is use for controlling current & voltage of Inverter.

abc to dqo Transformation:

Fig-5 shows the closed-loop DQ transformation system. The controller produces, reference signal. By supplying gate pulse controller's switching device, it supports the inverter. The dq- to-abc translation & PWM approach are used to create the gate pulses. In order to maintain the stability of the system & the quality of power, it is also employed to manage the current. Utilize the dc-link voltage & the reference voltage, the control section calculates Idref from, external voltage controller. The reference signal is generated by the controller in this closed- loop system. This provides assistance to the inverter by the q axis component vq for a balanced 3-phase system is almost 0 when angle of PLL is locked. The phase detector (PD) is the term used to refer to the q axis attribute in the PLL circuit. To reduce the steady-state error, it makes use of the low-pass filter with the PI controller. Then, for system operation with unity power factor, iqref is set to zero. The control unit calculates the errors of direct axis component (idref & id) & the quadrature axis component (iqref & iq). Here, the errors are calculated using id and iq. The dq components are produced & converted to abc components for generate the gate pulses by regulating the errors with the current controller.

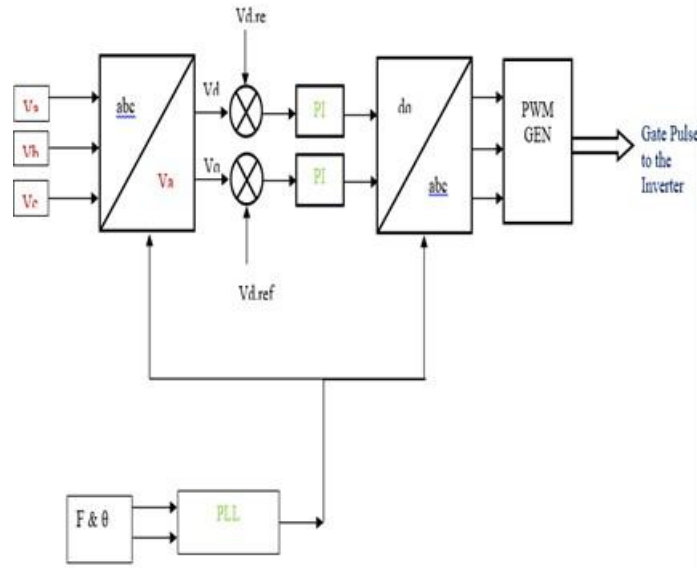

Figure 5- Block diagram of dq0 transformation

Shunt Active Power Filter

The Filter is use for reduce the harmonics & improve the power quality. Among the different available filter configuration, shunt Active power filter is used in this dissertation Work. This filter is designed such way that compensates the harmonics & enhances the performance of the system. This filter measure source voltage & load current to find the harmonics which are injected from the load side. Active power filter generate a harmonic current which are difference between load current and source current.

Active power filter classified based upon its connection, topology wise and also phase wise. Based upon its connections manner, classify shunt APF & series APF. It is classified phase wise like single phase and three phase and based on topology 3- phase three wire 3- phase four wire. Active power filter is not only for harmonic mitigation but also use for power factor correction, sag and swell compensation etc.

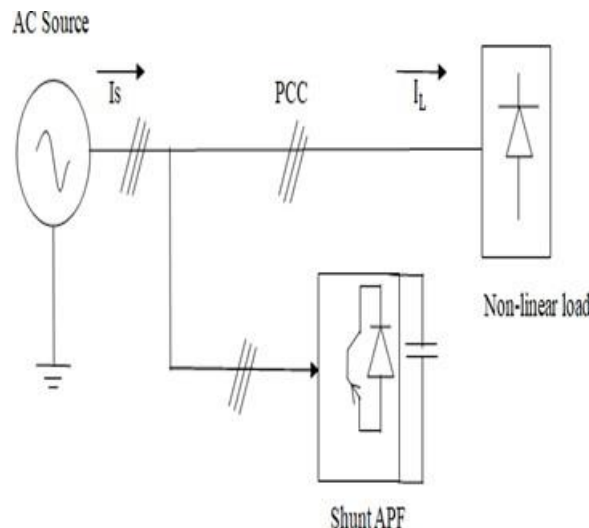

Figure-6 Block diagram of Shunt APF

This filter measure source voltage & load current to find the harmonics which are injected from the load side. Active power filter generate a harmonic current which are difference between load current and source current. Active power filter classified based upon its connection, topology wise and also phase wise. Based upon its connections manner,

classify shunt APF & series APF. It is classified phase wise like single phase and three phase and based on topology 3-phase three wire 3- phase four wire. Active power filter is not only for harmonic mitigation but also use for power factor correction, sag and swell compensation etc.

IV. SIMULATION & RESULTS

Fig-7 is a DC Micro grid system connected with Shunt Active Power filter it consists following sub system & parameters.

- PV Array
- Boost Converter
- Inverter
- abc to dq Transformation
- Bidirectional Converter
- Shunt Active power filter
- Lithium ion battery

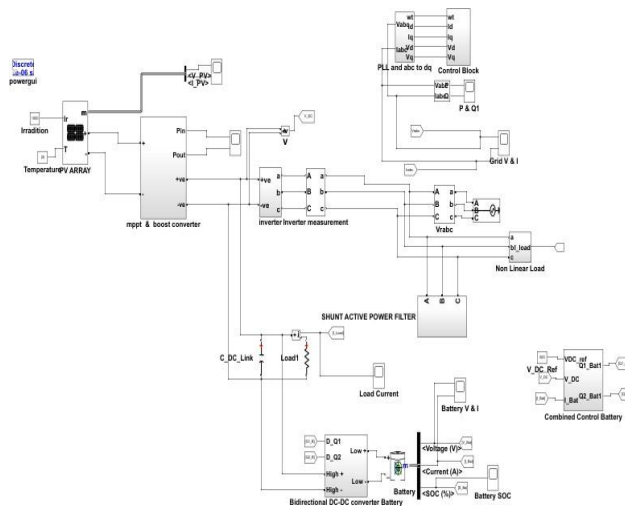

Figure-7 Simulation of DC Micro grid System

Sir. No	Parameter	Value
1	Parallel string	12
2	Series- connected string	9
3	V max	30.2V
4	I max	8.06A
5	V total	271.8V
6	I total	96.72A

Table-1 Parameters of PV array

Calculation of PV array:

Parallel string = 12

$$\text{Series – Connected string} = 9 \text{ V total} = 9 * 30.2$$

$$= 271.8$$

$$I \text{ total} = 12 * 8.06$$

$$= 96.72$$

$$\text{Power} = V * I$$

$$= 271.8 * 96.72$$

$$= 26 \text{KW}$$

Simulation of DC to DC Boost converter:

Fig-8 shows Design of PV connected DC to DC Boost converter which is used for boost up the PV panel voltage Using MPPT Technique for this purpose P&O Technique is use. Input of this boost converter is output of PV array.

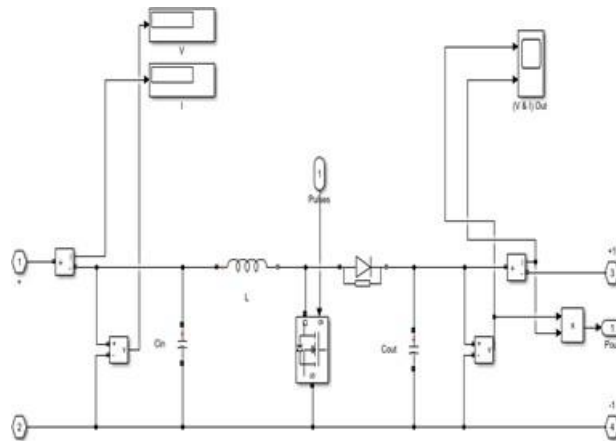

Figure-8 Simulation of PV connected DC to DC Boost converter

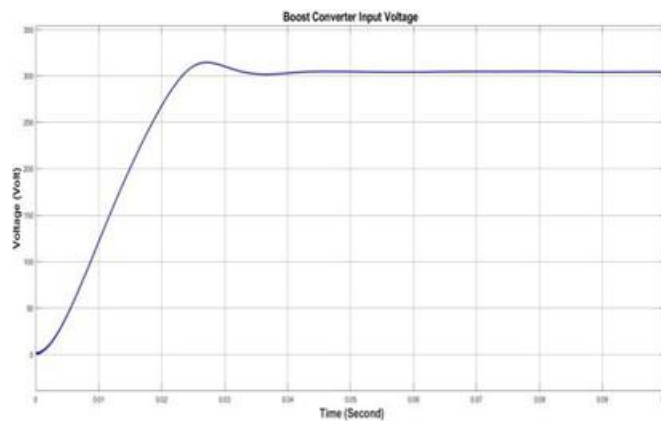

Figure-9 Boost Converter Input Voltage [304.2V]

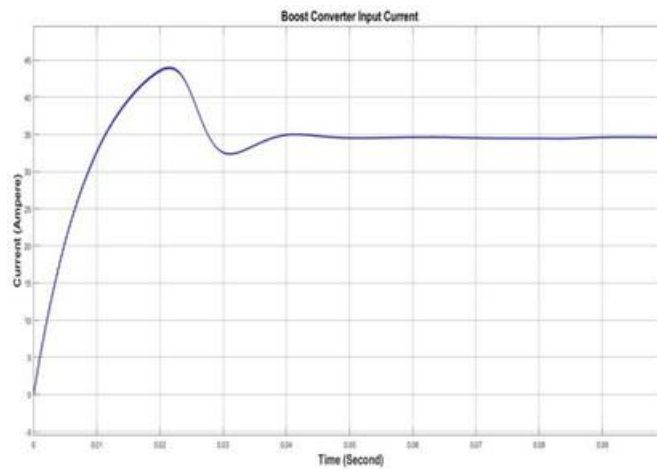

Figure-10 Boost Converter Input Current

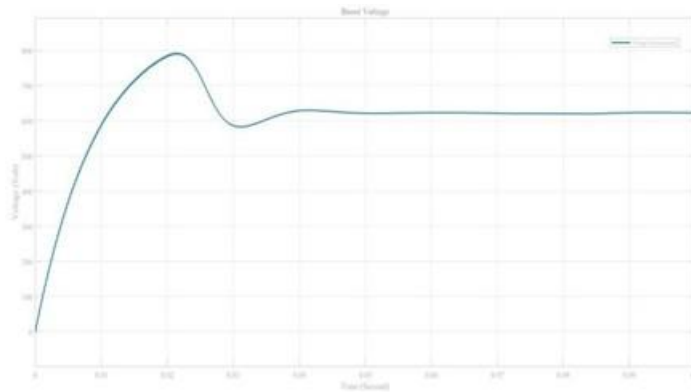

Figure-11 Boost Converter output Voltage [623.5V]

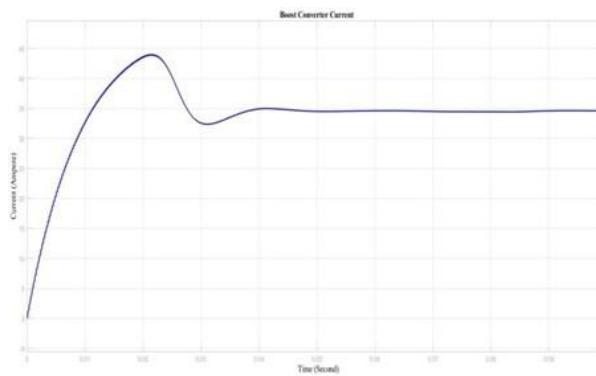

Figure-12 Boost Converter output Current [34.64 A]

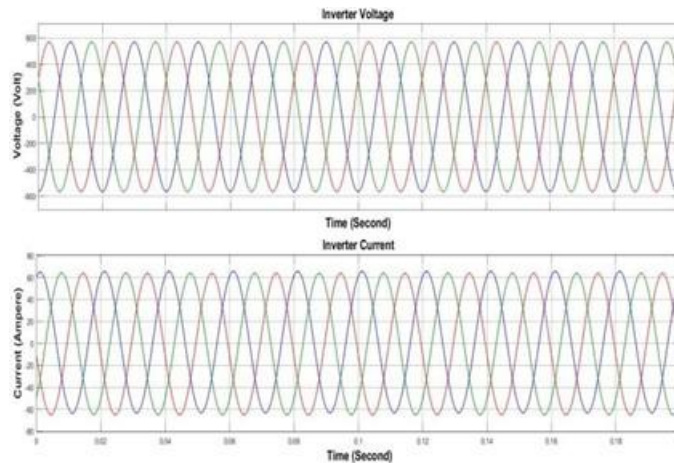

Figure-16 Inverter Voltage [400V] & Current [62A]

The dq-to-abc conversion & (PWM) approach are used to create the gate pulses. Utilize the dc-link voltage & reference voltage, the control section calculates i_{dref} from the outer voltage controller. i_{qref} is then set to zero. Figure 5.4.3 Show the Output Graph of Inverter, it is a close loop system to control the Current & Voltage of Inverter Using PLL and dq transformation, the value of voltage is 400V & value of Current is 60A.

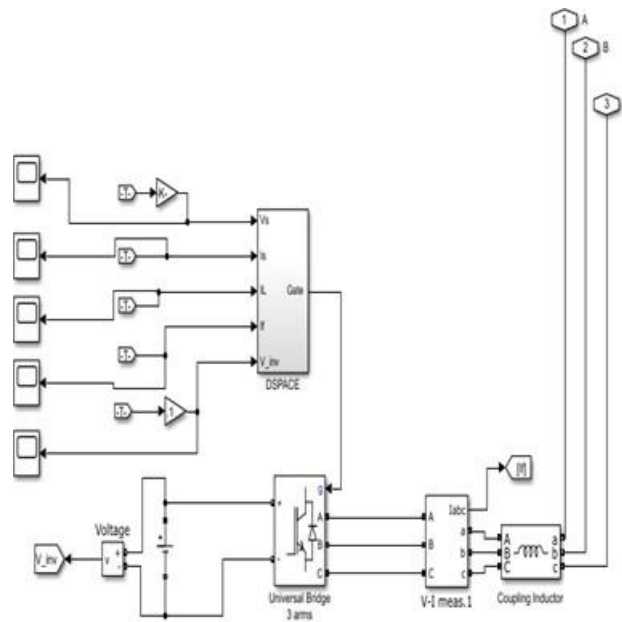

Figure-17 Shunt APF Simulation design

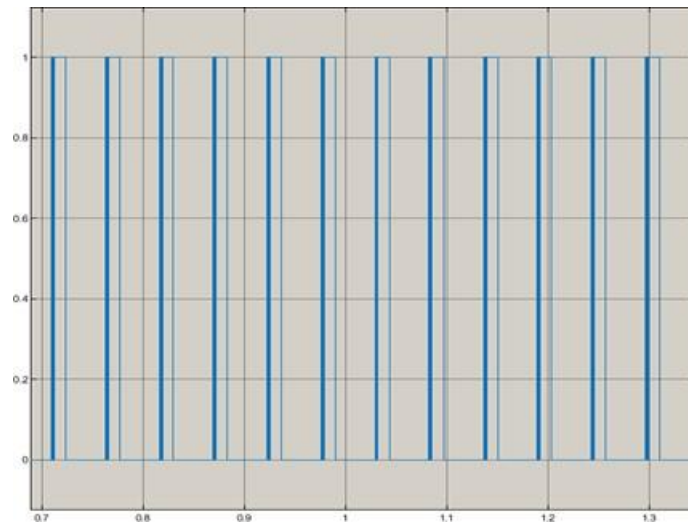

Figure-18 Switching Pulse of Q1

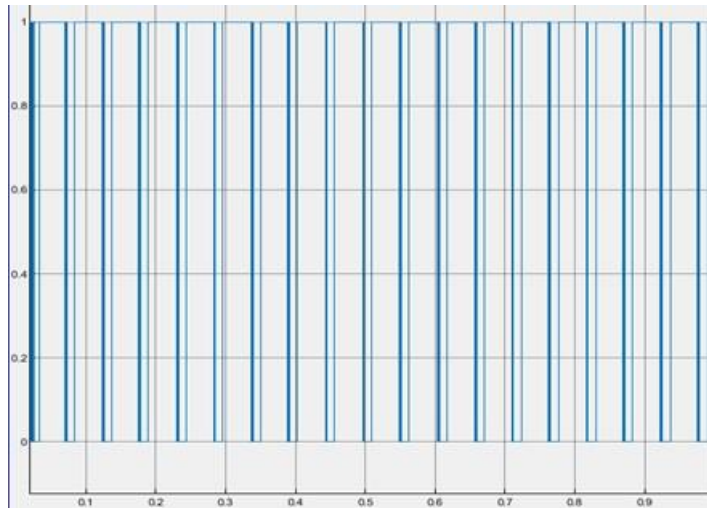

Figure-19 Switching Pulse of Q2

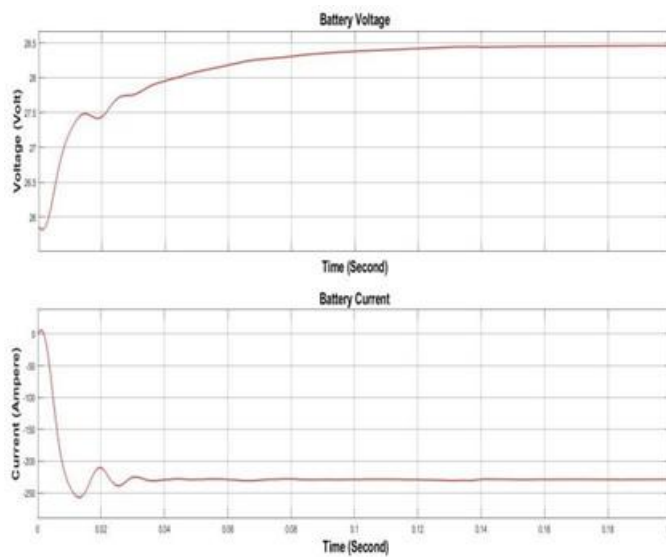

Figure-20 Voltage & Current Characteristic in Charging Mode

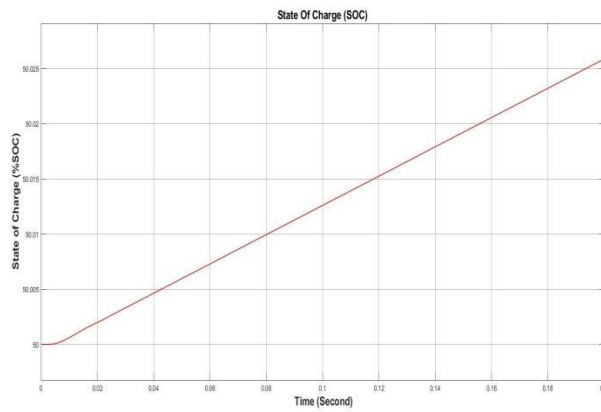

Figure-21 Battery SOC

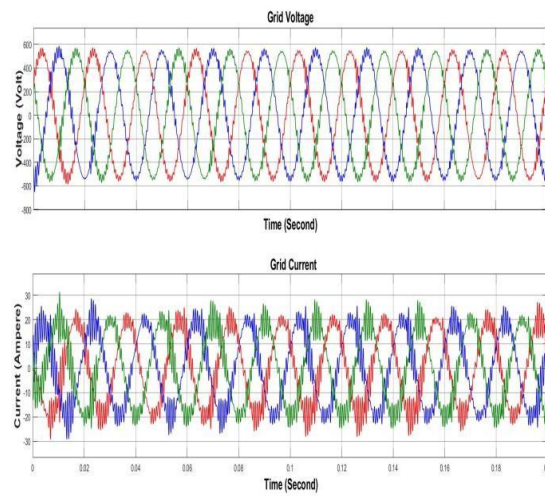

Figure-22 Grid Voltage and Current

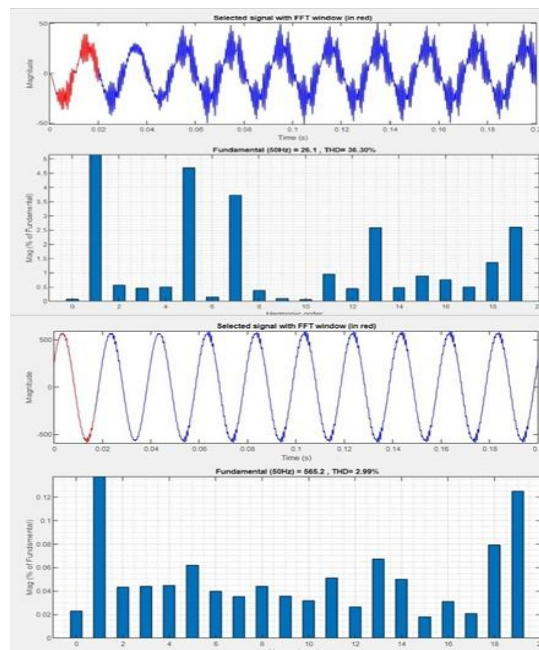

Figure-23 THD of Current without Filter

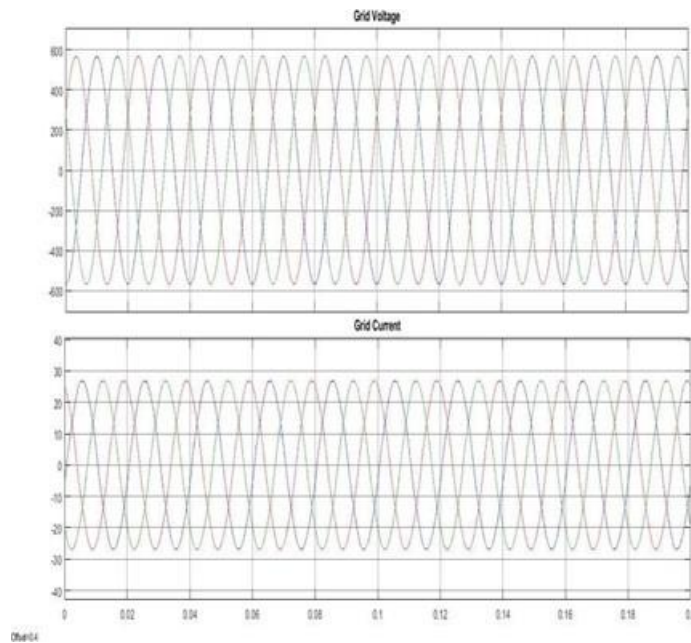

Figure-23 Grid Voltage [400V] & Current [20A]

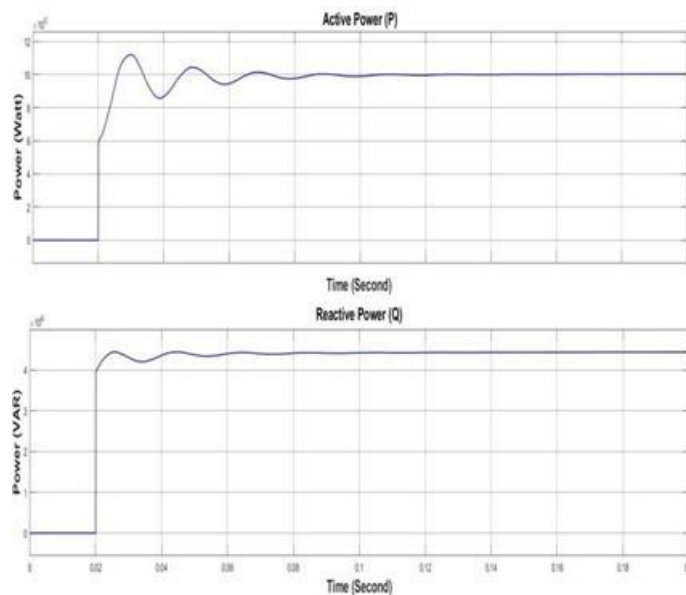

Figure-24 Active & Reactive Power of Grid

CONCLUSION

Important facets of renewable energy source have been observe in this paper and investigation have been done into the DC micro grid system. It is efficiently increase , power transfer effectiveness of a solar PV structure with dc micro grid thorough design and analysis have been putout, 27 kW PV array, an P&O MPPT, a boost converter, inverter shunt APF and Some different controlling Techniques have been suggested. Some power quality issues are faced when we integrated inverter circuit with pv ,like increse or deceace vale of current,voltage waveform fluctuation atc. It is mitigate Inverter Harmonics by connecting simple LC Filter & Mitigate Grid harmonics using Shunt Active Power Filter, the suggested converter reduces element losses & improves the efficiency of the entire structure. furthermore, P&O MPPT approaches are proposed. P&O offers the fastest dynamic reactions with the quickest irradiance changes and the highest maximum power points (MPPT). Also Battery is Connected to our bus for storing the energy. The suggested Filter helps in Mitigate Load current THD as well as reduse Grid Voltage & Current THD. Additionally, the grid-tied PV system's dynamic response was good. Overall, it showed in terms of load change reaction , grid current's

capacity to track references, injected grid current THD, & control of lower order harmonics. The proposed controller might therefore be a strong contender for alternative topologies of various applications, including the grid integration of RESs, & microgrids systems. The suggested Filter will be improved & increase the effectiveness of the grid-connected renewable energy system with experimental validation.

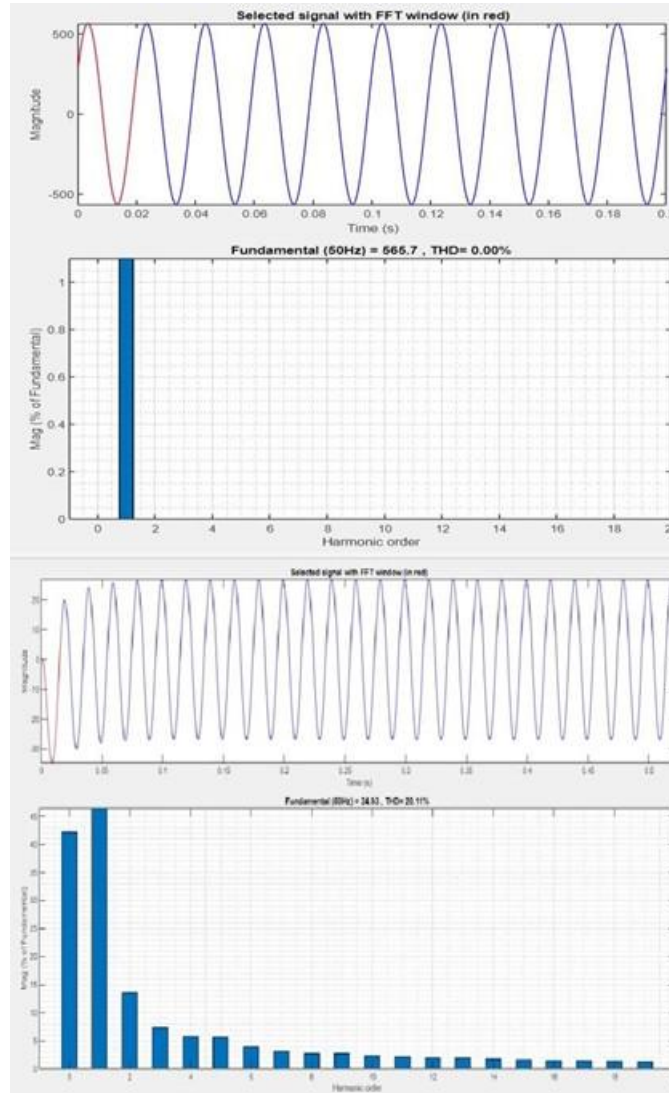

Figure-25 THD of Voltage & Current with Filter

REFERENCES

[1] Nejabatkhah and Y. W. Li, "Overview of Power Management Strategies of Hybrid AC/DC Microgrid," in IEEE Transactions on Power Electronics, vol. 30, no. 12, Dec. 2015, doi: 10.1109/TPEL.2014.2384999.

[2] V. Narayanan, S. Kewat and B. Singh, "Standalone PV- BES-DG Based Microgrid with Power Quality Improvements," 2019 IEEE International Conference on Environment and Electrical Engineering and 2019 IEEE Industrial and Commercial Power Systems Europe, 2019, pp. 1-6, doi: 10.1109/EEEIC.2019.8783251.

[3] D. Kumar, F. Zare and A. Ghosh, "DC Microgrid Technology: System Architectures, AC Grid Interfaces, Grounding Schemes, Power Quality, Communication Networks, Applications, and Standardizations Aspects," in IEEE Access, vol. 5, pp. 12230-12256, 2017, doi: 10.1109/ACCESS.2017.2705914.

[4] J. Sivaprakash, J. Sunil Abu, 2012, Power Quality Improvement In Microgrid Using Active Power Conditioner, International Journal Of Engineering Research & Technology (IJERT) Volume 01, Issue 09 (November 2012),

- [5] Julio J. Melero, Jorge Bruna, Javier Leiva, "On-site PQ Measurements in a Real DC Micro-grid", 2022 20th International Conference on Harmonics & Quality of Power (ICHQP), pp.1-5, 2022
- [6] Yang Zhou and C. Ngai-Man Ho, "A review on Microgrid architectures and control methods," 2016 IEEE 8th International Power Electronics and Motion Control Conference (IPEMC-ECCE Asia), Hefei, 2016, pp. 3149-3156, doi: 10.1109/IPEMC.2016.7512799
- [7] H. Samanta et al., "Development of a novel controller for DC-DC boost converter for DC Microgrid," TENCON 2019 - 2019 IEEE Region 10 Conference (TENCON), Kochi, India, 2019, pp. 1124-1129, doi: 10.1109/TENCON.2019.8929521
- [8] N. Sakthi and M. Kowsalya, "Power quality improvement features on photovoltaic grid connected dual voltage source inverter," 2017 International Conference on Communication and Signal Processing (ICCSP), 2017, pp. 1744-1748, doi: 10.1109/ICCSP.2017.8286691.
- [9] R. Aryan, R. Ranjan and A. Kumar, "Primary Control Strategies for Power Sharing and Voltage Regulation in DC Microgrid: A Review," 2020 3rd International Conference on Energy, Power and Environment: Towards Clean Energy Technologies, 2021, pp. 1-6, doi: 10.1109/ICEPE50861.2021.9404516.
- [10] J. Jiao, R. Meng, Z. Guan, C. Ren, L. Wang and B. Zhang, "Grid-connected Control Strategy for Bidirectional AC-DC Interlinking Converter in AC-DC Hybrid Microgrid," 2019 IEEE 10th International Symposium on Power Electronics for Distributed Generation Systems (PEDG), 2019, pp. 341-345, doi: 10.1109/PEDG.2019.8807601.
- [11] N. Femia, G. Petrone, G. Spagnuolo and M. Vitelli, "A Technique for Improving P&O MPPT Performances of Double-Stage Grid-Connected Photovoltaic Systems," in IEEE Transactions on Industrial Electronics, vol. 56, no. 11, pp. 4473-4482, Nov. 2009, doi: 10.1109/TIE.2009.2029589.
- [12] N. Sakthi and M. Kowsalya, "Power quality improvement features on photovoltaic grid connected dual voltage source inverter," 2017 International Conference on Communication and Signal Processing (ICCSP), 2017, pp. 1744-1748, doi: 10.1109/ICCSP.2017.8286691.